

SPD-M

Surge Protective Device Module

SM20(30)M230L306 Series

Description



Surge Protective Devices Module (SPD-M) is an onboard surge protection module. Integrated thermal protection, overvoltage protection and remote signal functions. A single module may have common mode, differential mode or full mode protection.

Integrated module can simplify the design and selection for users, suitable for low-voltage AC or DC power supply.

SETsafe | SETfuse SM20(30)M230L306 series are mainly composed of varistor (MOV), Gas Discharge Tube (GDT), flame retardant case and other metal accessories. Features such as compact size, high integration, and full protection functions. TUV certification and complied with RoHS and REACH.

Features

- High Reliability
- Small Size
- Combination Technology of ATCO, MOV and GDT
- Comply with UL 1449 / IEC 61643-11
- Differential-mode / Common-mode Protection

Applications

- Telecom Equipment
- AC / DC Power Supply
- Uninterruptable Power Supply (UPS)
- Surge Protective Device (SPD)

Dimensions (Unit : mm)

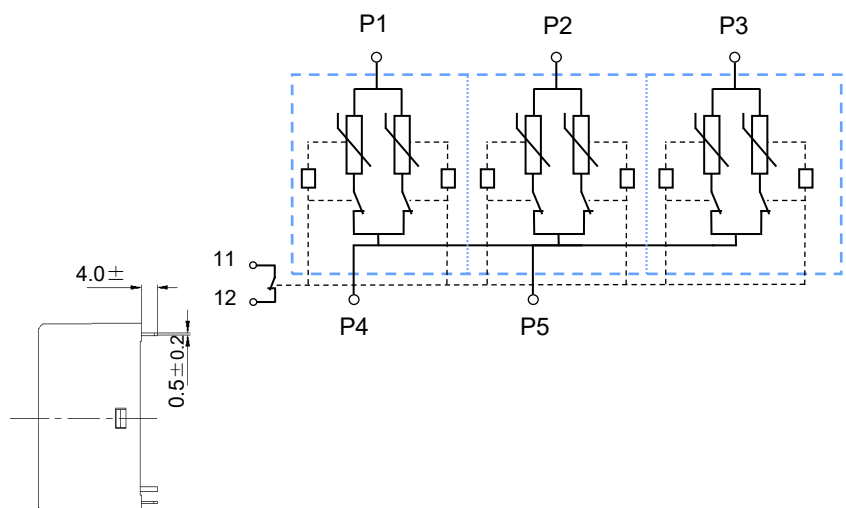
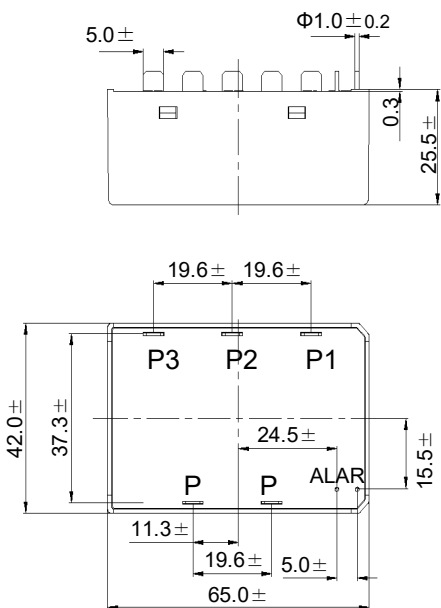

SPD-M

Surge Protective Device Module

SM20(30)M230L306 Series

Specifications

Features	Specifications	
Model	SM20M230L306	SM30M230L306
Nominal system Voltage (U_n)	230 / 400 VAC	230 / 400 VAC
Max. Continuous Operating Voltage (U_c)	385 VAC	385 VAC
Nominal Discharge Current (8/20 μ s) (I_n)	20 kA	30 kA
Max. Discharge Current (8/20 μ s) (I_{max})	40 kA	60 kA
Voltage Protection Rating (U_p)	1800 V	2000 V
Protection Mode	(L - PE) / (L - N)	(L - PE) / (L - N)
Alarm	Remote signal	Remote signal
Max. Main-side Overcurrent Protection	125 A gL/gG	
Installation	PCB	
Operational Temperature Range	(-40 ~ 85) °C	
According to Standard	IEC/EN 61643-11 Class II	

Wiring Diagram

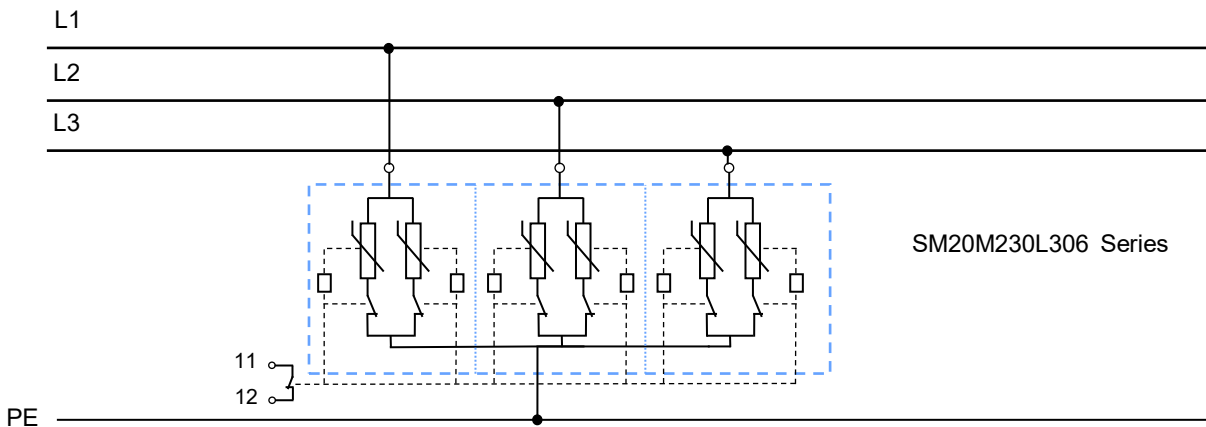
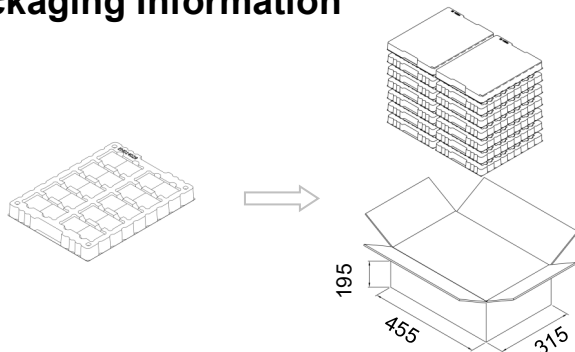

FIGURE 1 Three-phase circuit protection (20 kA)

Packaging Information



Unit: mm

Please contact us if you have special packaging requirements.

Item	Tray	Carton
Dimensions (mm)	295 × 220	455 × 315 × 195
Quantity (PCS)	60	240

SPD-M

Surge Protective Device Module

SM20(30)M230L306 Series

Agency Information

Agency Symbol		Standards	The File No. and certification No. obtained by SETsafe SETfuse	Category
	TUV	IEC/EN 61643-11	On going	Class II
Environment	EN	RoHS & REACH	Compliant	

Part Numbering System

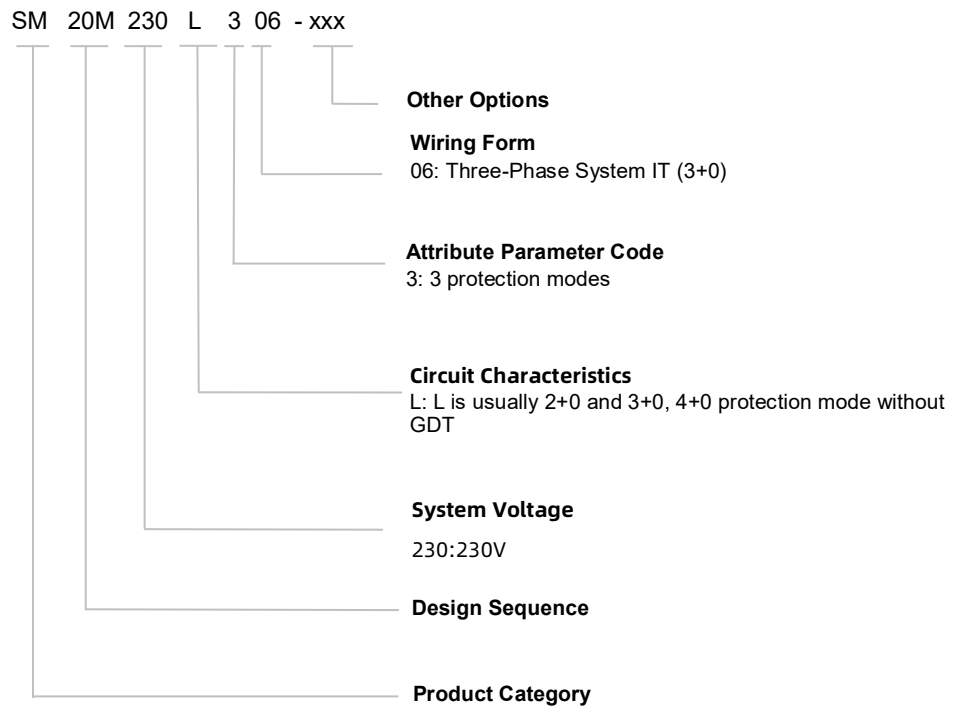

Reminder:

Part numbering system in the datasheet is only for selecting correct parameter and product features. Before placing order, please contact us for specifications and use the part number and product code in the specifications to place order to ensure the part is correct. Product code is the unique identification.

SPD-M

Surge Protective Device Module

SM20(30)M230L306 Series

Application Options

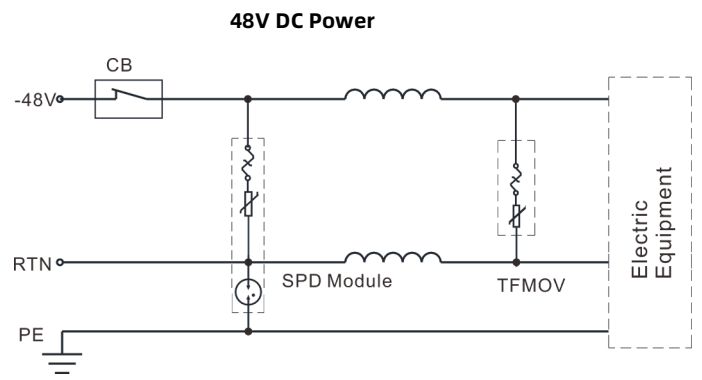
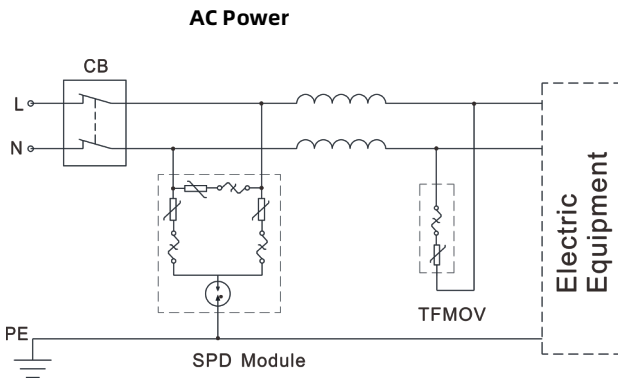

Wave Soldering Parameters (Reference)

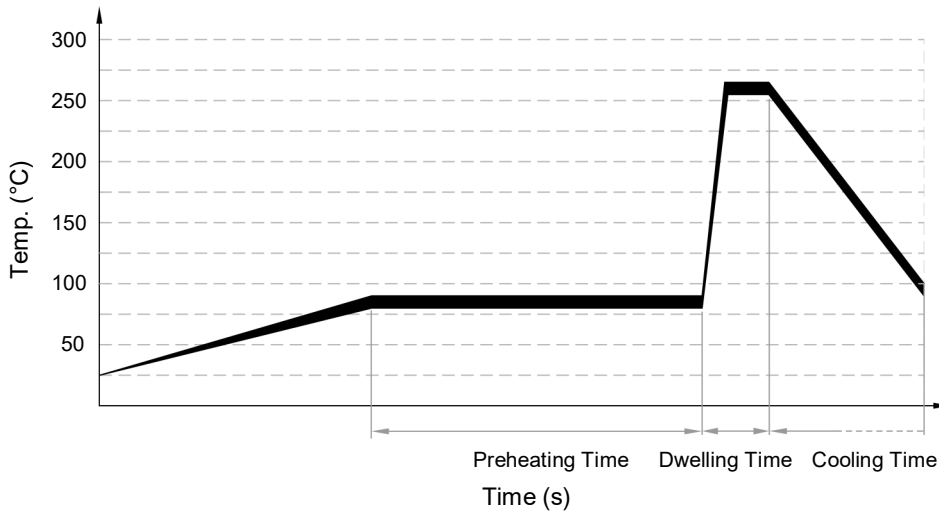

Item	Temp. (°C)	Time (s)
Preheating	≤ 150	60 ~ 150
Dwelling	≤ 260	≤ 10

Note:

The wave soldering parameters are for reference only. Before SPD-M is for practice usage, relative validation is recommended.

Recommended Hand-Soldering Parameters

Item	Condition
Iron Temperature	350 °C (Max.)
Soldering Time	4 seconds (Max.)
Distance between Soldering Point and the Bottom of Product	2 mm (Min.)

Glossary

Item	Description
U_p	<p>Voltage Protection Level Maximum voltage to be expected at the SPD terminals due to an impulse stress with defined voltage steepness and an impulse stress with a discharge current with given amplitude and wave shape. — (IEC 61643-11)</p>
8/20 μ s	<p>8/20 Current Impulse Current impulse with a nominal virtual front time of 8 μs and a nominal time to half-value of 20 μs. — (IEC 61643-11)</p>
1.2/50 μ s	<p>1.2/50 Voltage Impulse Voltage impulse with a nominal virtual front time of 1,2 μs and a nominal time to half-value of 50 μs. — (IEC 61643-11)</p>
U_c	<p>Maximum Continuous Operating Voltage Maximum r.m.s. voltage, which may be continuously applied to the SPD's mode of protection. — (IEC 61643-11)</p>
I_n	<p>Nominal Discharge Current Crest value of the current through the SPD having a current waveshape of 8/20. — (IEC 61643-11)</p>
I_{imp}	<p>Impulse Discharge Current for Class I Test Crest value of a discharge current through the SPD with specified charge transfer Q and specified energy W/R in the specified time. — (IEC 61643-11)</p>
I_{max}	<p>Maximum Discharge Current Crest value of a current through the SPD having an 8/20 waveshape and magnitude according to the manufacturers specification. I_{max} is equal to or greater than I_n. — (IEC 61643-11)</p>
Modes of Protection	<p>Modes of Protection An intended current path, between terminals that contains protective components, e.g. line-to-line, line-to-earth, line-to-neutral, neutral-to-earth.</p>
IP	<p>Degrees of Protection Provided by Enclosure (IP Code) Classification preceded by the symbol IP indicating the extent of protection provided by an enclosure against access to hazardous parts, against ingress of solid foreign objects and possibly harmful ingress of water.</p>
TCO	<p>Thermal-Link A non-resettable device incorporating a THERMAL ELEMENT which will open a circuit once only when exposed for a sufficient length of time to a temperature in excess of that for which it has been designed.</p>
ATCO	<p>Alloy Thermal-Link Alloy Type Thermal-Link, Alloy is the thermal element.</p>



ATTENTION

Usage

1. Frequency range is from 47 Hz to 63 Hz a.c.
2. The voltage applied continuously to the SPD-M must not exceed its maximum continuous operating voltage U_c .
3. When atmosphere press is from 45 kPa to 106 kPa, the related altitude shall be from 5000 meters to - 500 meters.
4. Do not touch the product body or pins directly when power is on, to avoid electric shock.

Replacement

As SPD-M is a non-repairable product, for safety sake, please use the same type of SPD-M for replacement.

Storage

Do not store SPD-M at high temperature, high humidity or corrosive gas environment, to avoid oxidation of the lead wires. Use them up within 1 year after receiving the goods.

Installation Position

Do not install SPD-M to the place that may suffer severe vibration.

Surge Protective Device Module (SPD-M) Feature & Model List Overview

Rated Voltage U_n (V)		Model	Nominal Discharge Current I_n (kA)		Maximum Continuous Operating Voltage U_n (V)		Page		
			5	10	15	20	AC	DC	
347V	400V							510	
						SM34S751P1GBB		460	
254 - 277V								420	
		SM15S621P3*BB				SM34S621P1GBB		385	
220 - 230V		SM15S561P3*BB				SM34S561P1GBB	SM34S561P2*B#	350	
		SM15S511P3*BB				SM34S511P1GBB	SM34S511P2*B#	320	
		SM15S471P3*BB				SM34S471P1GBB	SM34S471P2*B#	300	
						SM34S431P1GBB	SM34S431P2*B#	275	
								250	
								230	
120 - 130V								210	
								190	
		SM15S271P3*BB					SM34S271P2*B#	175	
		SM15S241P3*BB				SM34S241P1GBB	SM34S241P2*B#	150	
110V		SM15S221P3*BB					SM34S221P2*B#	140	
		SM15S201P3*BB					SM34S201P2*B#	130	
								115	
								95	
60V	60V							75	100
				SM34S121P1GBB	SM20K121P1*BA			60	85
48V				SM34S101P1GBB	SM20K101P1*BA			50	65
				SM34S820P1GBB	SM20K820P1*BA			40	56
36V			SM34S680P1GBB		SM20K680P1*BA			35	45
								30	38
24V			SM34S470P1GBB						
	24V								

Notes:

- * May be followed by G or N.
- # May be followed by B or A.

Surge Protective Device Module (SPD-M) Feature & Model List Overview

Rated Voltage U_n (V)	Model	Nominal Discharge Current I_n (kA)				Page
		15	20	30	AC	
347V	400V	○	○	○	○	510
		○	○	○	○	460
220 - 230V	254 - 277V	SM15M277A203	SM20M230A203	SM20M230%	SM30M230%	420
		○	○	○	○	385
110V	120 - 130V	SM15M230A203	SM20M277A203	SM08B230N203	○	350
		○	○	○	○	320
48V	60V	○	○	○	○	300
		○	○	○	○	275
24V	36V	○	○	○	○	250
		○	○	○	○	230
AC		○	○	○	○	210
		○	○	○	○	190
AC		○	○	○	○	175
		○	○	○	○	150
AC		○	○	○	○	140
		○	○	○	○	130
AC		○	○	○	○	115
		○	○	○	○	95
AC		○	○	○	○	75
		○	○	○	○	60
AC		○	○	○	○	50
		○	○	○	○	40
AC		○	○	○	○	35
		○	○	○	○	30

Notes:
% May be followed by L205, L306 or A404.